



6,00



SUOMI·FINLAND





SIGILLUM CAPITULI KUOPIOENSIS
HOC SIGNO VINCES
1851



(SKR 695) (£69.50)



Identifiable by colors
& vertical hatching around
figure 12.

1878

1866
no dividing
lines

1878

Reprint
1881

Reprint
1881

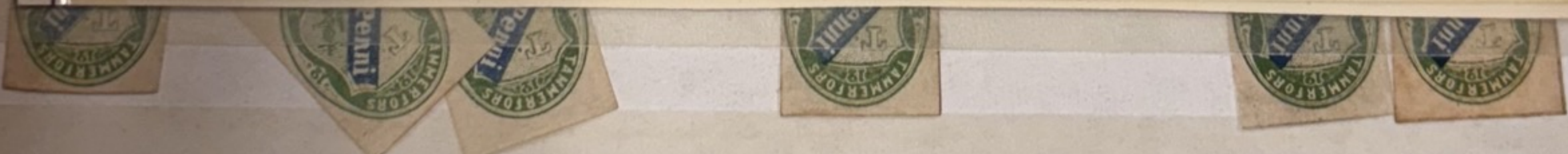



proofs

Rep I



Rep II



Rep III



H'sinki Locals

5p Ring Type
Unissued

5p Ring Type, Line perf 11.5

This stamp was designed for a new, cheaper rate, but never issued before the service closed.

Again, a 9 unit group in a 100 unit sheet, layout same as the 10p, except for position 100, which is now type 1.



11, Type 9
Brown/light brown/gold



10p Ring Type, Line perf 11.5

This stamp had a number of essays in 5 different colors.
Arrangement of the 9 types in the sheets of 100 as below.
Double ring large type cancel, rare single ring bi-lingual.



10
Bluish green/
pale orange/gold



5 6



1. No specific signs.
2. N of KAUPUNGIN and the foot of the central "1" broken.
3. Dot in the lower left corner of the upper left value-pane.
4. P of POSTI broken.
5. H of HELSINGISSÄ damaged.
6. P of KAUPUNGIN broken, frame-line broken below Ä of PENNIA.
7. H and L of HELSINGFORS damaged.
8. Frame-line broken to the left of the upper left "10".
9. Frame-line broken to the left of lower left "10".

1	2	3	1	2	3	1	2	3	1
4	5	6	4	5	6	4	5	6	4
7	8	9	7	8	9	7	8	9	7
1	2	3	1	2	3	1	2	3	2
4	5	6	4	5	6	4	5	6	5
7	8	9	7	8	9	7	8	9	8
1	2	3	1	2	3	1	2	3	3
4	5	6	4	5	6	4	5	6	6
7	8	9	7	8	9	7	8	9	9
1	2	3	4	5	6	7	8	9	4



R12 postmark

84

R11

15

2B_a



2B_c

2B_d

NIA 85

GAN



2/2 H



2/5 H



NIA

20/1/85-A

N2B 10/3/85-B

DJERNA 4/11/85-2

1

2

85

11/8 H



87

17/1/87-A



12/4 D

12/4 H



24/12/86

88
2/1/87 H

89

12/2/87



12/5 H

90 1/10

BA... 12/12/86

H'sinki Locals

Small Oval Type
1884-1891

Small Oval Type, Line perf 11.5

Long life. 7 shades reported.
7 'constant' varieties reported.

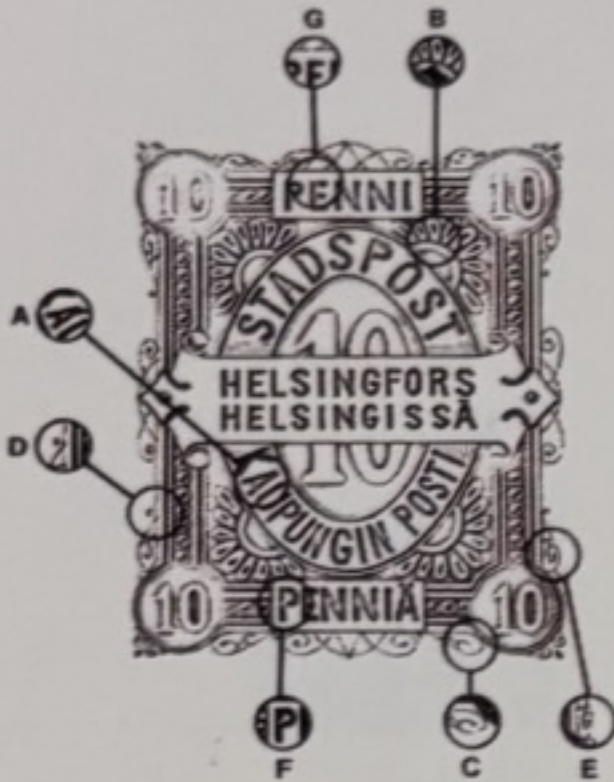

- Suggested characteristics of the intermediate types:
- ✓ A. Protrusion on A of KAUPUNGIN.
 - ✓ B. Upper right flower ornament deformed.
 - ✓ C. Broken ornament at the lower frame-line near the right "10".
 - ✓ D. Broken ornament above the lower left "10".
 - E. Ornament above the lower right "10" flattened and mostly broken
 - F. White dot in P of PENNIA.
 - G. Frame-line broken above E of PENNI.
 - ✓ H. No specific signs.



Small Oval 9a *A*
Or-brown Aug 1884
Small type



Small Oval 9b
brown Jan 85
12/13/85 - J
Small type



Small Oval 9c
reddish-brn July 85
21/12/88



Small Oval 9d *H*
Or-brn March 86
5/3/1886



Small Oval 9e *H*
olive-brn March 87
17/4/87
Small type



Small Oval 9f *D*
dark brn Feb 88
12/4/88
LARGE



Small Oval 9g-*C*
brown Feb 1889
LARGE



MINI

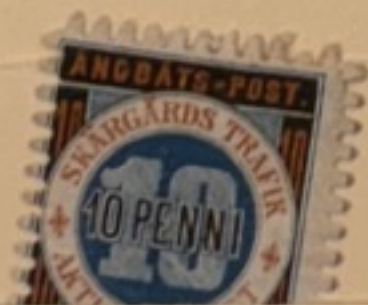
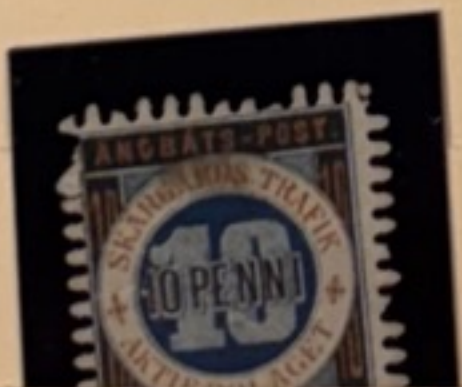

FINLAND

1925.

Sommaroarnas Trafik Aktieföretaget.
(The Summer Islands Transport Co. Ltd.)

Perf 11½.

Lithographed in sheets of 8.





1884.

Helsingfors Local Post.

Perf 1 1/2.

Lithographed on tinted paper by

F. Silgman & Co.



E3



D



D



E3

D



FINLAND

1884 - 1888

Helsingfors Local Post.

Perf 11½.

Lithographed on tinted paper by
F. Tilgman & Co.,

B



}



11/1/85



8/4/89



98/5/11



21/3/86



12/7/85

B



2/11/85

D



18/1/11



58/5/22



F

12/3/85

FINLAND

21st April, 1890.

Helsingfors Local Post.

Cover for delivery to Maurity-gatan,

franked 10 pennia brown on

yellow grey, perf 11 1/2.

Stamp lithographed.

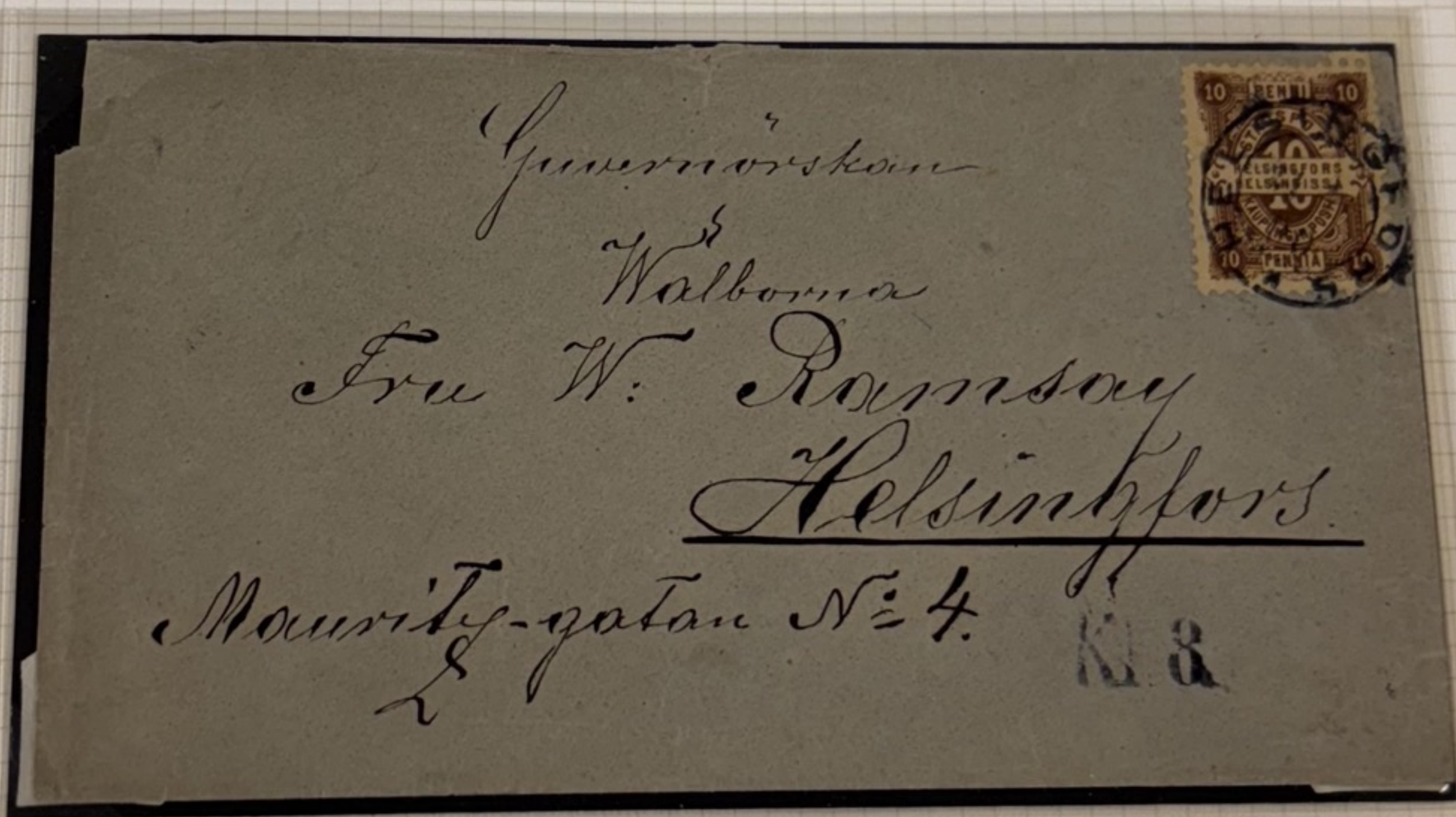

FINLAND

13th March, 1890.

Helsingfors Local Post.

Cover for local delivery franked with
10 pennia, brown on yellowish grey,
perf 11½.



FINLAND

7th August, 1889.

Helsingfors Local Post.

cover for local delivery franked
with 10 penni brown stamp perf 11½.



D + TR O=C

Stamps were lithographed on tinted
paper by F. Tilgmann.

1st January, 1889.

Helsingfors Local Post.

cover for delivery to Michaelsgatan
franked with 10 penni stamp, brown
on greenish grey, perf 11 1/2.

Stamp lithographed by F. Tilgmann.



Handlanden

H. Herr K. H. Renlund

K. 8

Michaelsgatan No 8.

H'sinki Locals

Diagonal Type
Stone VI

Line Perf 11.5



7 VI a

Brownish red/dark green, Dec 1881

D/4 '82



'81

7 VI b

Orange red/dark green, June 1882

d/3



7 VI c

Aniline red/dark green, OCT 82

Z 8 JAN 82

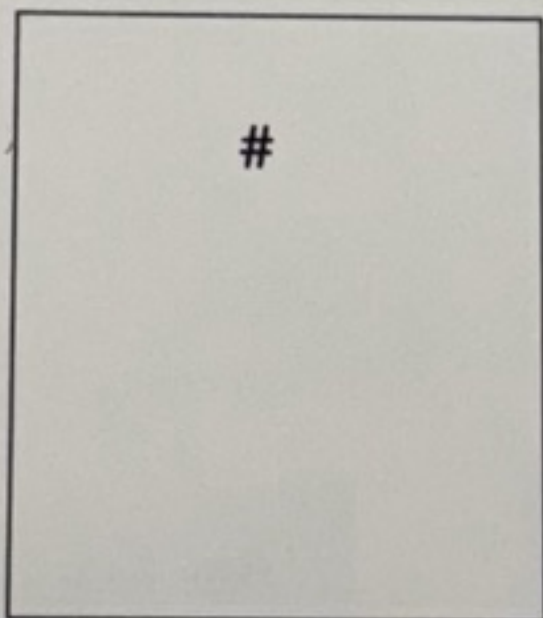
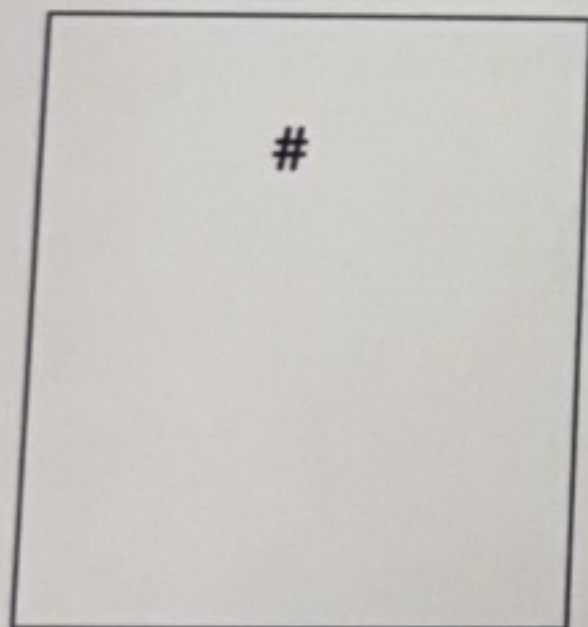
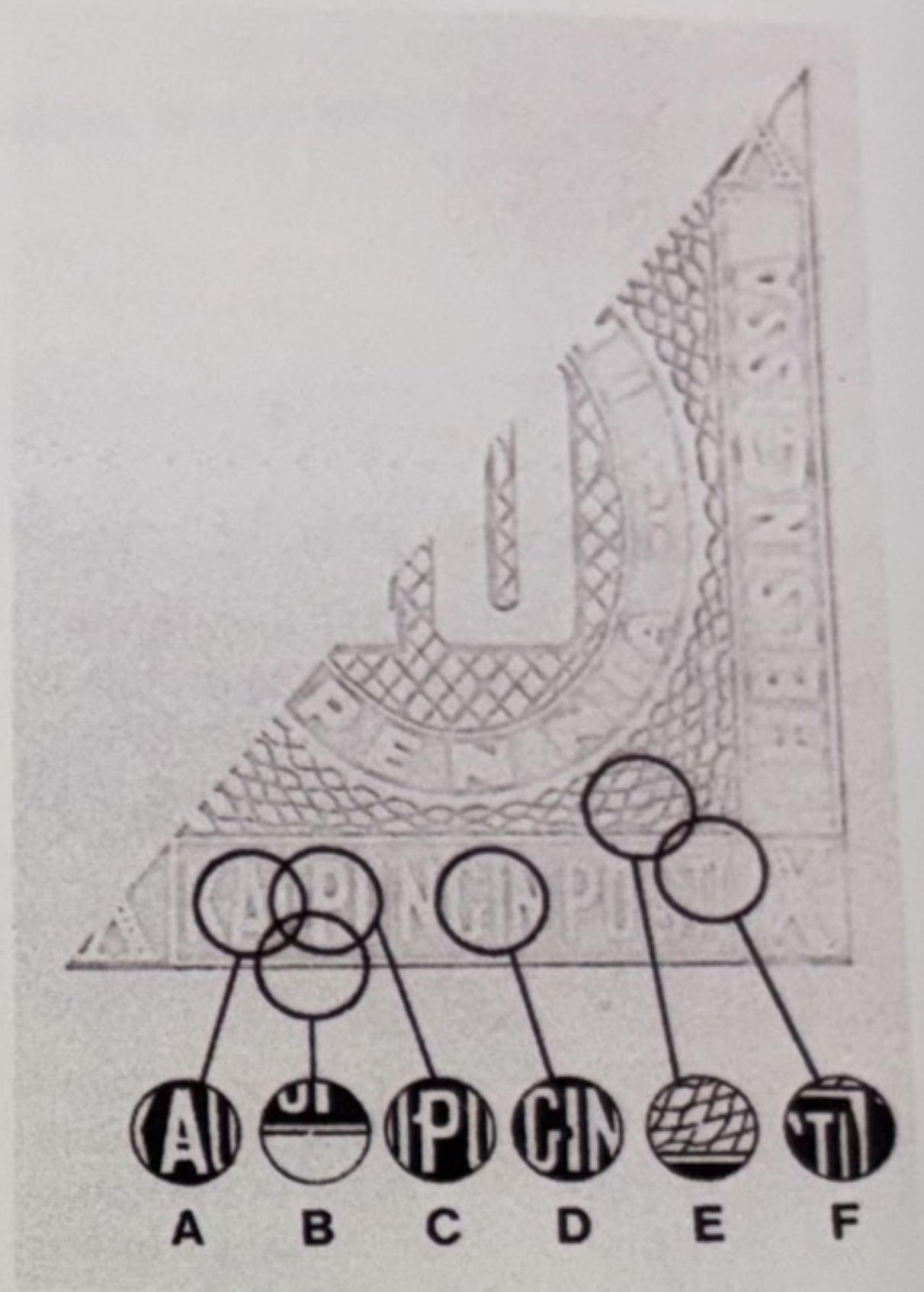
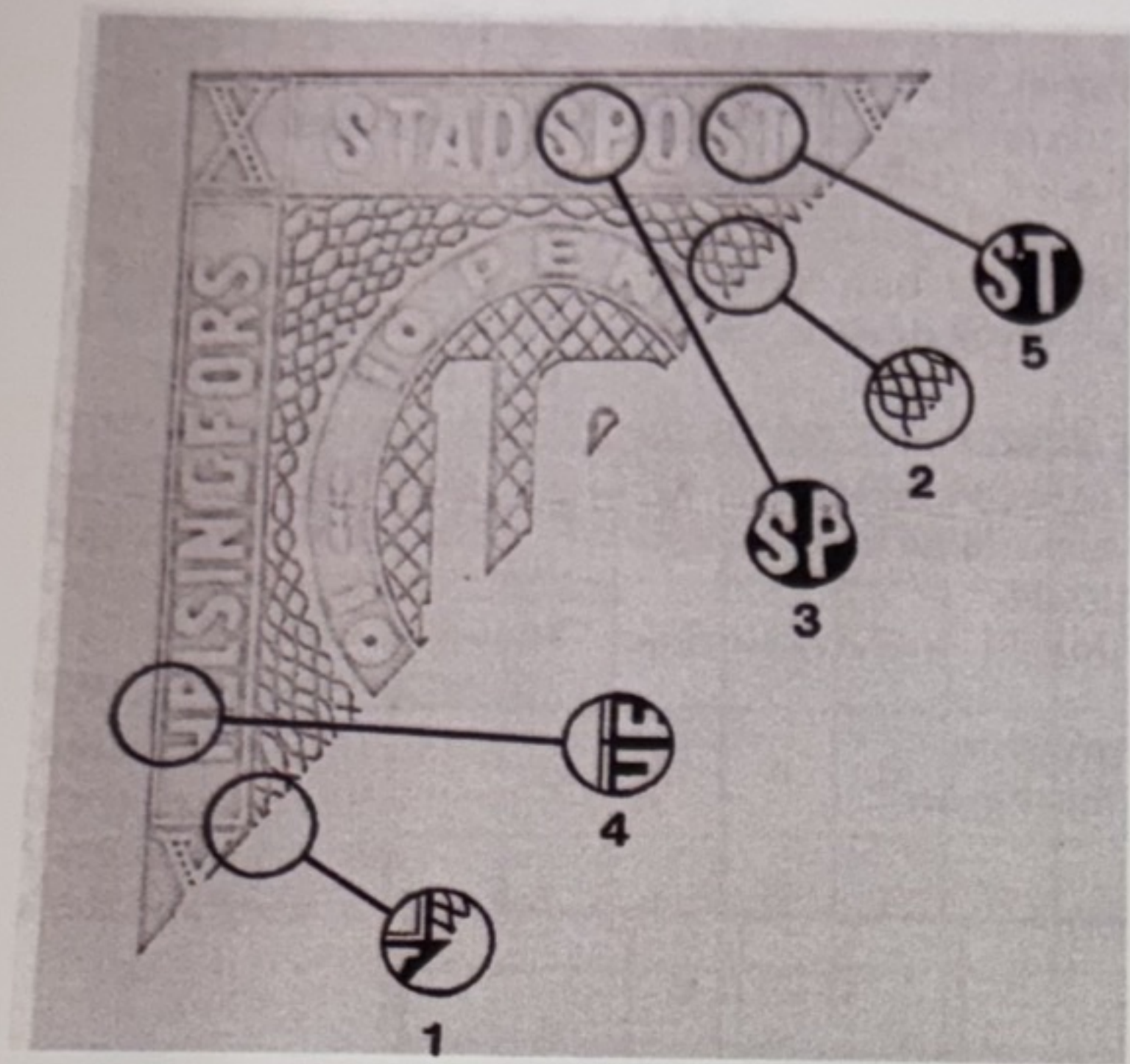

H'sinki Locals

Diagonal Type Reprints

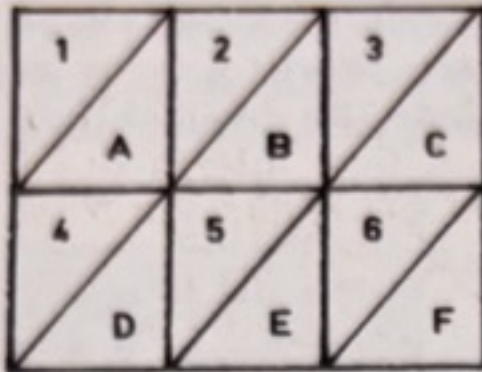

Normala kombinationer
Normal combinations

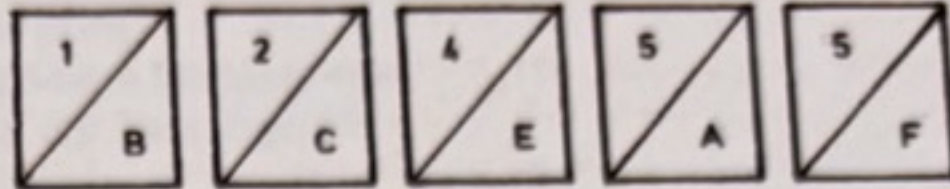

Onormala kombinationer
Unnormal combinations



1A



2B



3C



4D



5E

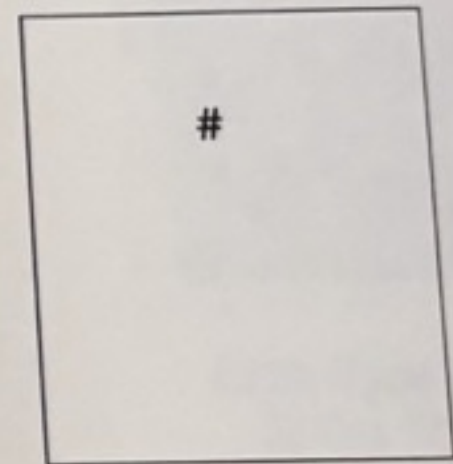

6F

Abnormal

4/D

5/E

Abnormal
1/B, 2/C,
4/E, 5/f

BR corner block



1/B

H'sinki Locals

Coat of Arms Type
1883-4

Coat of Arms, Line perf 11.5

Red/bluish green. Cancels are small double-ring in black.

Very short life of 1 year. Used are scarce, and mint even harder to find.

Emmerfors gives 8 intermediate types, but 3 out of my 7 are Type C!

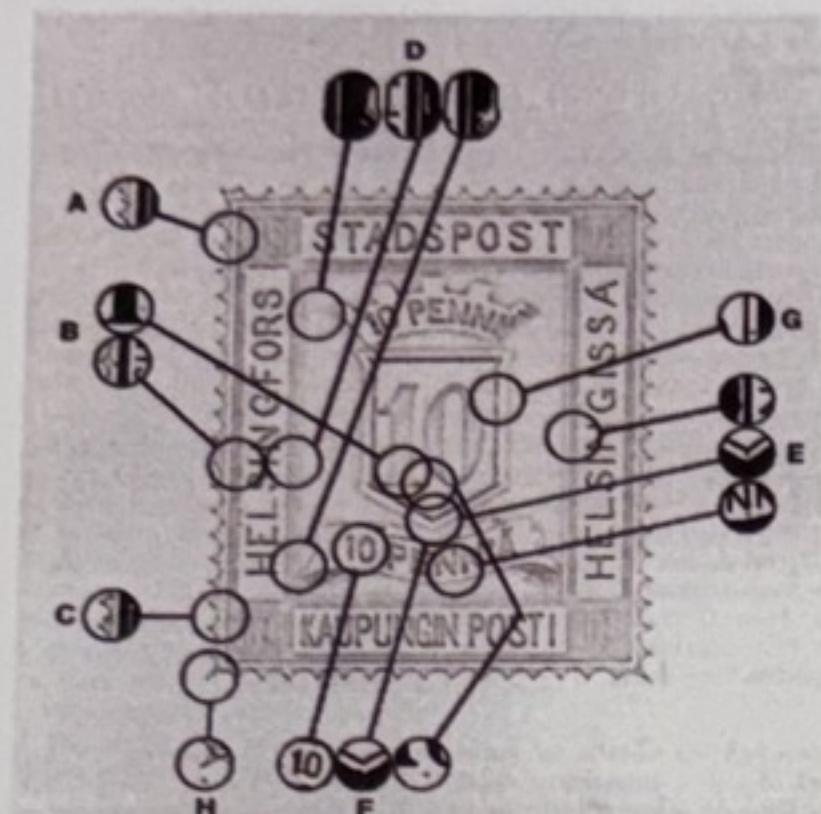

	Description	Location
A	Red dot	Left margin by upper '10'.
B	Short vert line	Outer L frame L of SI and dot by R foot of large 1
C	Dot in L margin	by top of BL 1.
D	White spots	between H of HELSINGFORS and ribbon, plus dots to R of the I and R of same word.
E	Dot	Below R leg of N of Penniä, Extended point of inner frame of COA. Irregular frame L of N of Helsingissä.
F	Dot	Below 10 of lower 10 in ribbon. Below the large 10.
G	Stroke	Edge of COA opposite G of Helsingissä.
H	Green dot in margin	In margin below BL corner.



COA Mint



COA Type C
26Apr 84



COA Type C
12 Feb 84



COA Type C
12 Oct ??



COA
20 Jan 84



COA
3 April 84



COA
25 April 84

H'sinki Locals

Diagonal Type Stone VI

Stone VI. Line Perf 12.5, 1879-82

Cancels are grotesque or from Jan 18 81 double-ring cancel, purple or black.

In general, similar to Stone V, but there are 6 intermediate types probably a 6-unit group building the sheet. The green varieties (Vars A-F) are constant through all shades and prints, the red (Vars 1-6) are not, implying a change of the stone partway through.



	Description	Location
L	Two dots in background	Left of NN of Penni
M	Dot	To left of I of Penni
N	Dot	Left of right ornament and in center of that ornament
Q	4 dots	In N, O, and S and bottom L foot of right X at bottom
R	Open foot S	First S Helsingissa
S	Irregularities in background	Left of first S Helsingissa
T	Dot in white frame	Left of Ä of Helsingissa, with umlaut.

Line Perf 12.5



6 VI a
Orange-red/green, Mar 1879
F/G 1879-GA07 P5.



6 VI b
red/dark green Dec 1880
D4, 4 Dec 80



6 VI c Feb 81
pale red/dark green
21/MAR 81



6 VI d
red/dark green, May 1881
D/T 31 DEC 81

Stone IV. Rough Perf 12.5, 1875-8

Similar to Stone II. Loses Var A, retains Var B. Plus E from Stone III. Two new vars.

Seems that left stone is from II and right red stone from III?

Cancel Grotesque only, 1875 greyish-black, from 1876 in blue.

Generally wide margins



	Description	Location
B	Red Dot	E of PENNI
E	Closed bottom loop	In FIRST S of HELSING- ISSA
H	At least 1 dot	Over last A of Helsingissa
I	Dot in white outer frame line	Right of last A, and also over P at top



3 IV a

red/yellowish green, Sept 1875

BLA, 21 JAN 76

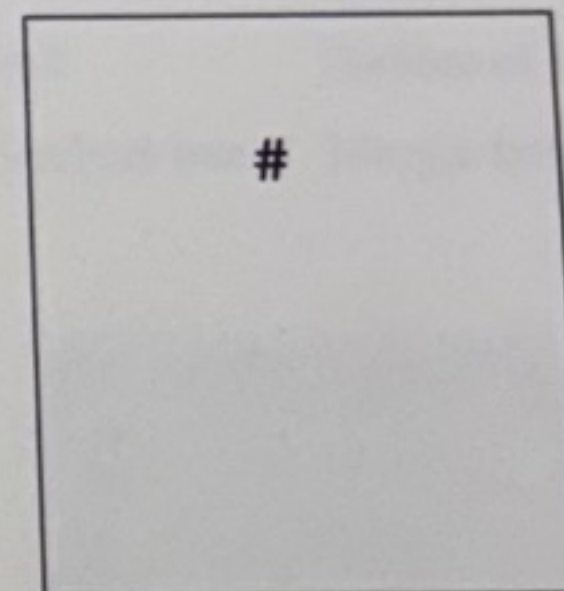

3 IV b

red/bluish green, Jan 1877

H'sinki Locals

Diagonal Type Stone V

Stone V. Line Perf 12.5, 1878-9

Cancel marks are all grotesque, in 1878 blue, from 1879 purple



	Description	Location
E	Closed bottom loop	In FIRST S of HELSING- ISSA
K	Lower left foot deformed	Lower right X
L	Two dots in back- ground	Left of NN of Penni
M	Dot	To left of I of Penni
N	Dot	Left of right ornament and in center of that ornament
O	White tail	Bottom of S of Posti
P	Small vertical line	Margin below G



5 V

Red/yellowish green, Jan 1878
Blue Grotesque 1878



5V

Red/yellowish green, Jan 1878
Purple Grotesque, Jan 79?

Stone II. Roulette c. 11 1873-5

This and following have both red and green lines between stamps.
Manuscript and antiqua (Serif) and grotesque (sans-serif) cancels known.
Var A plus 6 more constant flaws Vars B-G.
Some show traces of writing in the value figures.



	Description	Location
A	Horiz line	Under N of Hels
B	Red Dot	E of PENNI
C	Red Dot	S of STADS
D	Thin line	Cuts serifs of the X's
E	Closed bottom loop	In S of HELS
F	Red dot	Lower loop, left ornament
G	Thin angled line	up through H of Helsingissa



3IIa
light red/dark green June 73
12 Nov 73, Black Antiqua



3IIa
(Light) red/dark green
21 Apr 73, Black Grotesque



3IIb
Light red/pale bluish green Apr 74
?, Black Antiqua



3IIb
Light red/pale bluish green Apr 74
11 mar 75, black Grotesque

H'sinki Locals

Diagonal Type
Stone I

Stone I. Roulette c. 11 1871-3

Distinguished by having only a single green line separating the stamps.
Sometimes shows traces of the original lettering inside the large '10'.
Only black antiqua cancals known.
Only 1 flaw known, Var A.



3-I a
Red/bluish green, 1871



3-I b
red/dark green 1871



26 Aug 71



Traces of original lettering
visible at bottom of
the large '1' of value



26/9/73

H'sinki Locals

Large Oval type
Reprints

Type III A, roulette 11.25, short teeth

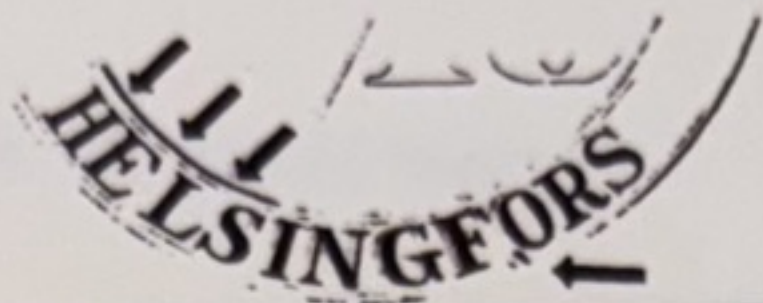

IIA 1a
Green/red



IIIA1b
Yellowish green/brick red



III 2a
Yellowish brown/dark blue



III 2b
Reddish brown/blue



H'sinki Locals

Large Oval type
Reprints

Type III A, roulette 11.25, short teeth

Type III C, Line roulette



III C 1
yellowish green/red



III C 2
Reddish brown/ ultra

Type III D, Perf 12.5



III D 1
Green/red

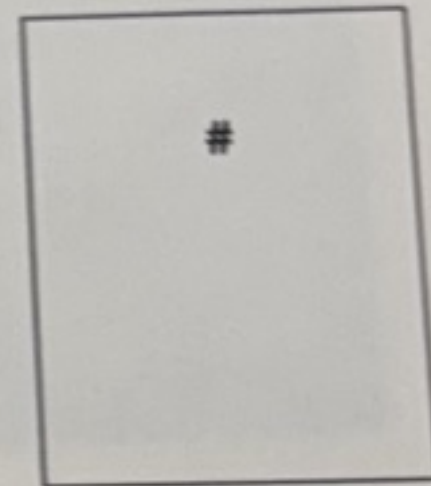

III D 2
Reddish brown/ultra

Type III E, Imperf



III E 1
Green/red

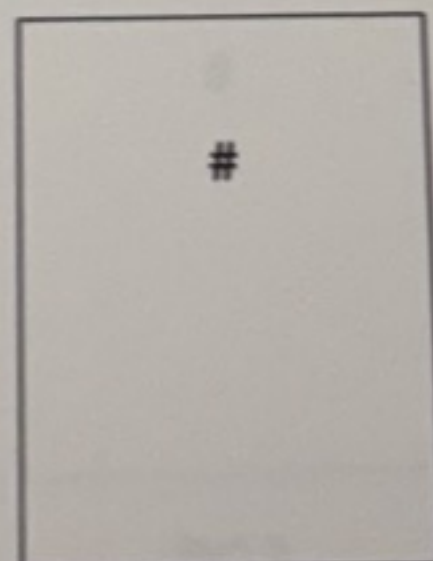

III E 2a
Reddish brown/
dark blue

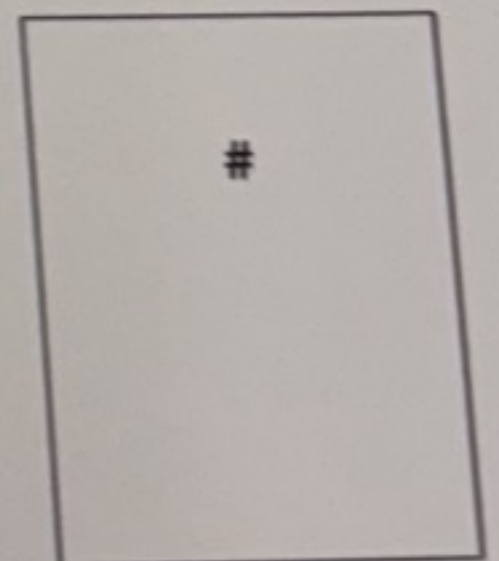

III E 2b
Yellowish brown/ultra

H'sinki Locals

Large Oval type
Imitations

Type E, 18 teeth in diagonal vs 16

18 teeth on diagonal, checkers in bottom too small, oval too narrow. Lines

Type E A 2, Roulette 10.75



EA 2
Light olive-brown/blue

Type E B, Perf 12.5



EB 1
Light green/red



EB 2
Light olive-brown/blue

H'sinki Locals

Large Oval type
Forgeries

Type FI 13 Teeth, not 16. Sawtooth roulette
Canceled with a square of dots. Probably Fournier.



FI-1
Green/red



FI-2
Red-brown/blue

Type FII Same as FI,
but with Frame line outside the 'Teeth'.
Cancelled with double ring cancellers, No date, two kinds of type.



FII-1
Green/light red



FII-2
Red-brown/light blue

2B
ad



2Bc

2Bd

NIIA2
KII

NIIA-1

16



NIIA

2a



3



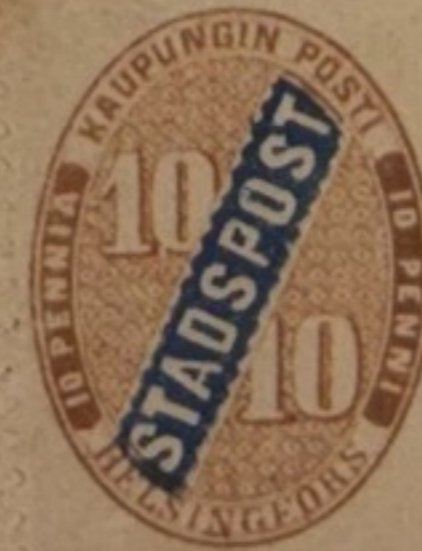
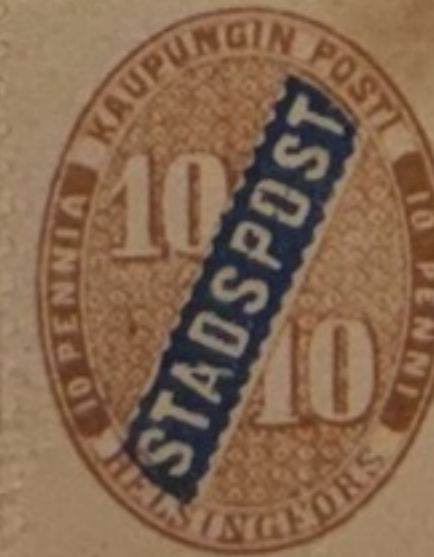
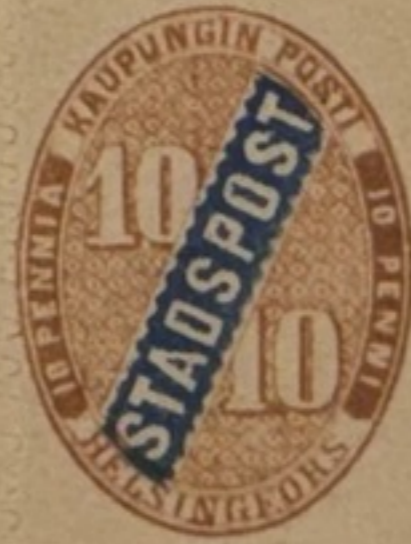
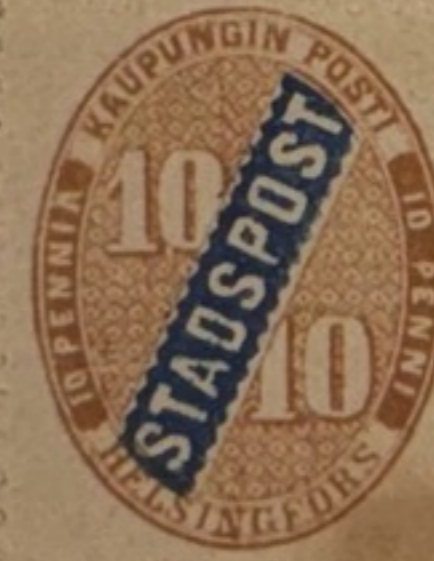
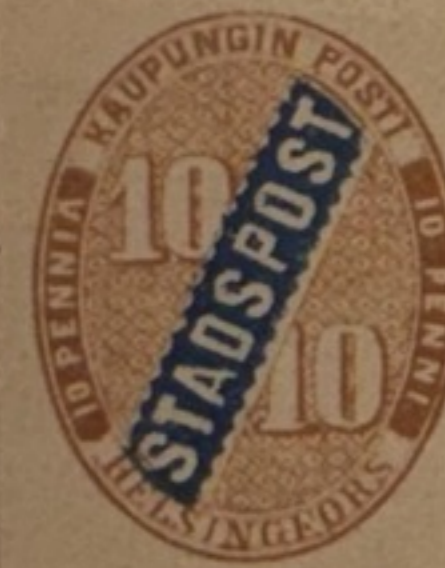
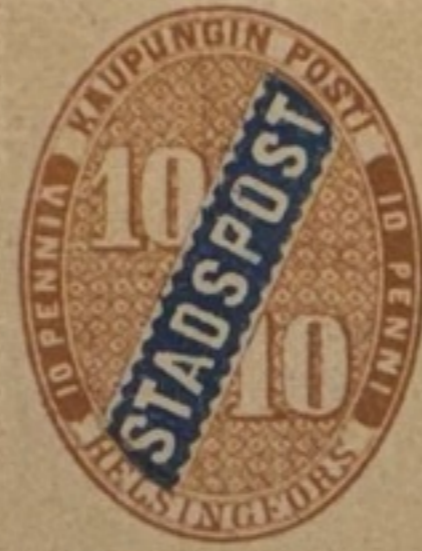
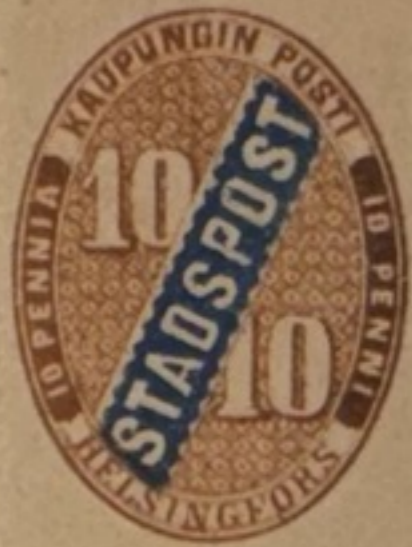
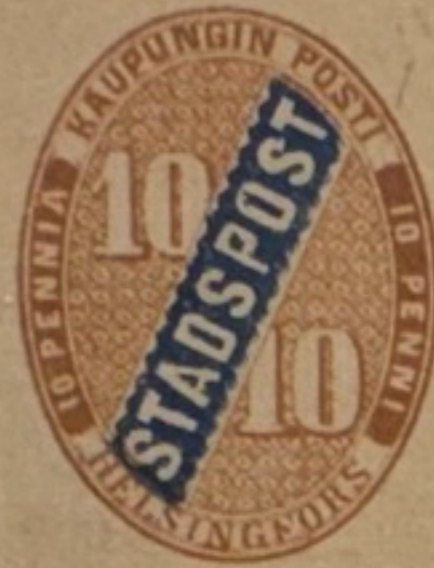
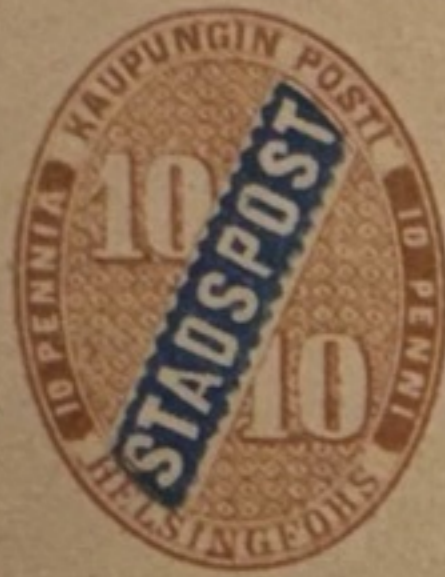



Type IIA, Roulette 11



IIA 1
Green/brick red



IIA 2
Reddish brown/ultra

Type IIB, Perf 12.5

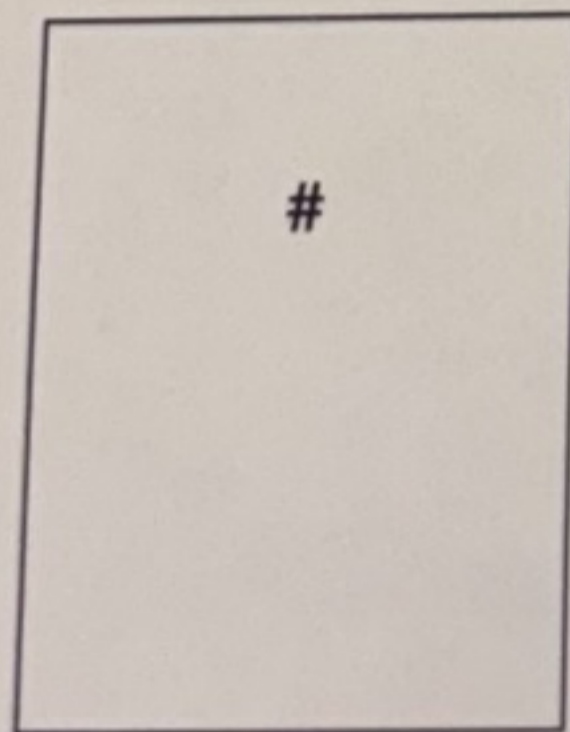

IIB 2
Reddish brown/ultra

Type IIC, Perf 11.5



NIIC 1
Green/brick red

Roulette 11

Green/Red



29/I/67!

1B 1868
Dark green/dull carmine

Brown/Blue



2B a 1868
Dark brown/dark blue



2B b
Brown/greenish blue



2B c, 1870
Brown/ultra greyish-blue
5/8/70



2B d, 1870?
Greyish brown/(light)blue

Roulette 12

Green/Red

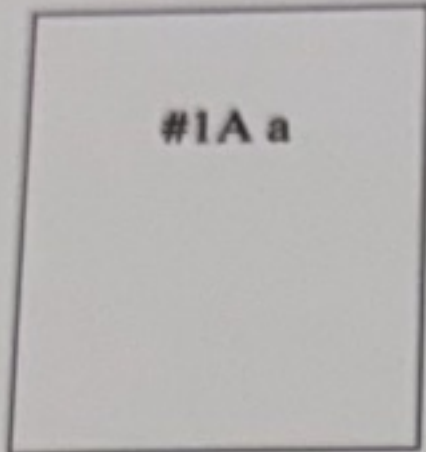

1Aa 1866
Dark Green/Dark Red

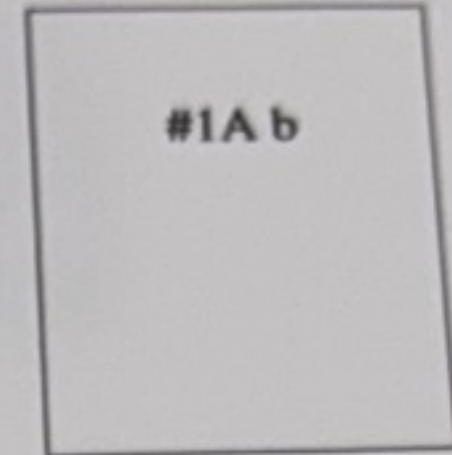

1Ab 1866
Yellowish green/red

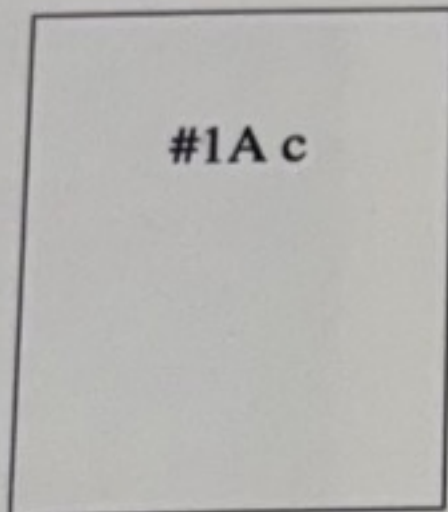

1A c, 1867
Green/Red

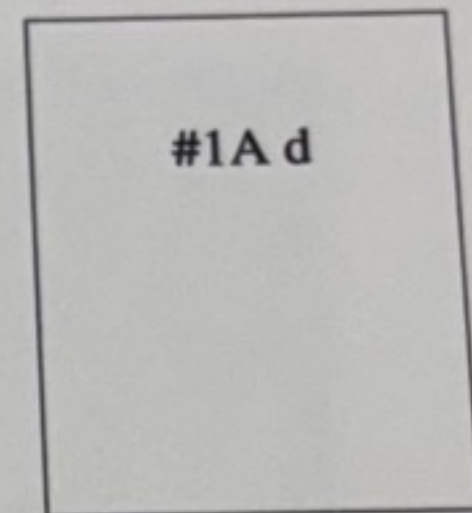

1A d, 1867
Dark green/dull carmine

Brown/Blue



2A a 1868
Dark brown/dark blue

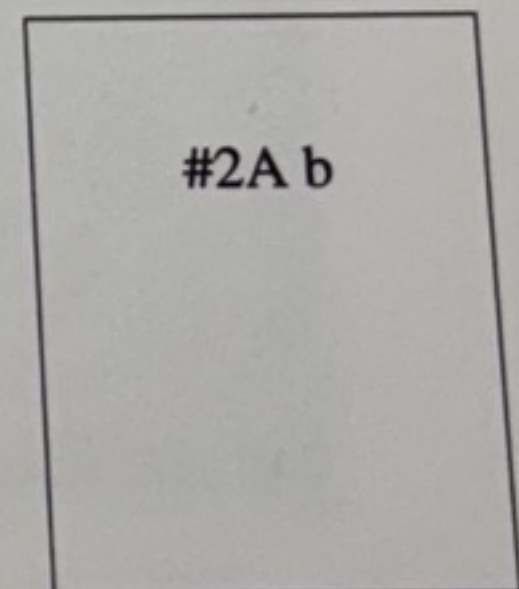

2A b 1868
Light Greyish brown/blue

THE 1968 WOODSTOCK CATALOGUE

ONLY FIVE DAYS AWAY

BY FAR THE MOST COMPREHENSIVE STUDY
OF ELIZABETHAN G.B. STAMPS YET
PRODUCED

ITS UNIQUE FEATURES INCLUDE :

- * Separate listing of the Green, Blue, and Violet Phosphor Definitives.
- * Complete lists of all known Cylinder numbers and Perforation Varieties.
- * Full details of all known Major Errors and Varieties, including the number of each known to exist.
- * Sections on Overprints, Air Letter sheets, and Local Carriage Labels.

For 16/6 post free (P.P.R. home or abroad), you can have 192 pages of well-organised information. Printed on fine art paper, with nearly 400 illustrations, the "WOODSTOCK" is THE ONLY SENSIBLE BUY for all grades of collector.

THE WOODSTOCK CATALOGUE COMPANY
13 VAUGHAN ROAD - - EXETER

MONTHLY POSTAL AUCTIONS

Singles, sets, collections (rare), unusual and specialist items

ALL COUNTRIES
FREE CATALOGUES

on request

RITTER & CO.

INTERNATIONAL AUCTIONEERS

2A ADAM AND EVE MEWS
KENSINGTON HIGH STREET
LONDON, W.8

We are always pleased to accept lots for our monthly auctions.

Only 10% commission plus postage

RITTER-AUCTIONS

NOT ONE! NOT TWO! NOT THREE! NOT FOUR!
NOT FIVE! NOT SIX! NOT SEVEN!

BUT EIGHT

VERY GOOD REASONS
WHY IT PAYS TO
SELL TO US

REASON 1.

Last year we bought over £100,000 worth of stamps. Our requirements for this year is even greater.

REASON 2.

75% of all our purchases are at auction. If only these collections had been offered direct to us the owners would have saved themselves the auctioneers commission and been spared long periods of waiting.

REASON 3.

Being situated in the Provinces we do not get as many "over the counter" offers as London dealers. We cannot therefore be as choosy. Almost without exception we buy everything offered to us.

REASON 4.

Our method of selling is to price each stamp individually for inclusion in our exchange club. We don't value only "The Plums" and let the rest ride with us. Consequently we can—and do—offer substantially more for collections.

REASON 5.

We have the cash available and pay in full by return of post.

REASON 6.

We are well-established dealers with a proud reputation of fair play to maintain. We are members of the B.P.A. and P.T.S. and have advertised regularly for years in this magazine.

REASON 8.

All offers we make hold good for at least one month. This gives owners plenty of time to try elsewhere before returning to us—as they almost invariably do—to accept our offer.

FOR HONEST TO GOODNESS OFFERS
ALWAYS SEND TO:—

URCH, HARRIS & CO. LTD. (SC.11/2)
7 Richmond Hill Ave,
Bristol, 8

GREAT BRITAIN—MINT (unless otherwise stated)

	Pl.	Ph.	Pl.	Ph.		Pl.	Ph.	Canada
1d.	1d.	1d.	Isle of Man		Sir W.	6/-	11/6	S.G.
1d.	2d.	2d.	2½d.	3/6	F.R.B.	2/9	—	31 u. 30/-
1½d.	3d.	3d.	3d.	4d.	Geog.	12/6	35/-	41 u. 65/-
2d.	3d.	3d.	4d.	9d.	5d.	Botan.	11/6	30/-
2½d.	4d.	4d.	Guernsey		Shakes.	15/-	21/6	51 u. 26
3d.	5d.	4d.	2½d.	3/6	Lister	4/6	5/6	54 u. 25/-
4d.	6d.	5d.	3d.	1/6	4d.	C. Arts	5/-	9/6
4½d.	7d.	7d.	4d.	5d.	—	S. Army	6/6	15/-
5d.	7d.	7d.	Jersey		700 Parl	9/6	4/6	101
6d.	9d.	8d.	2½d.	3/6	N. Wk.	4/-	8/6	115 u. 20/-
7d.	9d.	9d.	3d.	9d.	4d.	Paris	3/9	—
8d.	10d.	10d.	4d.	9d.	5d.	Lifeboat	15/-	—
9d.	11d.	11d.	N. Ireland		F.F.H.	10/6	—	119 u. 6/-
10d.	1/-	1/-	3d.	7d.	4d.	N.P.Y.	10/6	—
1/-	1/3	1/3	4d.	7d.	5d.	C.E.P.T.	3/9	—
1/3	1/6	1/6	6d.	8d.	—	61 Parl.	12/6	—
1/6	1/9	1/9	9d.	—	11d.	Europa	17/6	—
(17)	11/6	11/3	1/3	1/6	—	57 Graph	10/9	—
Scotland			1/6	—	1/9	58 Graph	—	—
3d.	4d.	4d.	Wales		(No 1½d.)	32/6	—	147 u. 29/6
4d.	5d.	5d.	3d.	7d.	4d.	Festival	2/9	—
6d.	8d.	8d.	4d.	7d.	5d.	Victory	1/6	—
9d.	—	11d.	6d.	8d.	—	Olymp.	7/6	—
1/3	1/6	1/6	9d.	—	11d.	Centy.	17/6	—
1/6	—	1/9	1/3	1/6	—	K.E.VIII	3/3	—
3d. (2 Band)	3/-	1/6	1/6	—	1/9	37½d.-3d.	8/6	—
F.D.C.								
'67 Xmas	..	—	Pl.	Ph.	Pl.	Ph.	POSTMARK	
Discoveries	..	—	—	5d.	—	2/3	Bethlehem	
Chichester	..	—	—	5/6	—	7/6	London	
Artists	..	—	—	2/-	—	5/-	Greenwich	
Flowers	..	—	—	3/3	—	6/-	London	
EFTA	..	4/6	4/6	6/6	6/6	6/6	London	
'66 Xmas	..	2/7	2/6	4/9	5/3	5/3	London	
Hastings	..	2/3	3/-	—	5/9	5/9	Bethlehem	
Technology	..	4/6	5/9	—	9/6	9/6	Battle	
Cup Winner	..	5/-	5/9	6/9	7/3	7/3	London	
Birds	..	2/-	—	10/-	—	—	London	
World Cup	..	2/-	2/9	—	4/9	4/9	London	
Landscapes	..	3/-	3/9	—	10/-	10/-	London	
Westminster	..	5/-	5/9	8/-	9/-	9/-	London	
Burns	..	7/6	1/-	9/-	—	—	S.W.1.	
U. Nations	..	3/-	4/-	4/6	5/6	5/6	London	
I.T.U.	..	3/6	4/6	6/6	7/6	7/6	London	
P.O.T.	..	4/-	15/-	6/6	19/6	19/6	London	
B.O.B.	..	2/9	4/6	6/6	7/6	7/6	London	
	..	8/6	10/6	15/-	19/6	19/6	Hitchin	

M. G. WOOLSTENHOLMES, 98 Walkern Road, Stevenage, Herts

HELSINGFORS FRIMÄRKSSAMLARE-FÖRENING

FINNLAND

III

HELSINGFORS

Stadtpost

TAMMERFORS

Lokalpost

AUSGABE 1923

